

Relative Humidity Module

HM1520 Low Humidity Sensor

HS1101 capacitive humidity sensor based on rigid packaging, HM1520 is designed for accurate measurement of low humidity environment. In environments where low humidity values are required, It can directly measure the dew point or moisture content. Because it is a linear voltage output humidity detection module, Therefore, it can be directly connected to the microcontroller.

Main Features

The wall-mounted immersion of the pipe has no effect on full interchangeability

Powered by 5VDC, 0~20%RH Typical output 1~1.6VDC calibration, Linear voltage output, Easy to electrically connect

Controllable temperature dependence

Proportional output to power supply voltage

Characteristics of Humidity Sensor

The solid polymer structure of the patent was not affected by prolonged exposure to low humidity

Fast response time

Maximum parameter (Ta=25°C, Unless otherwise specified)

parameter	symbol	parameter values	unit
Range of dew points	Td	-50~30	°C
service voltage (peak value)	Vs	12	Vdc
Humidity operating range	RH	0~100	%RH
Temperature operating range	Ta	-30~60	°C

HM1520 Precision curve

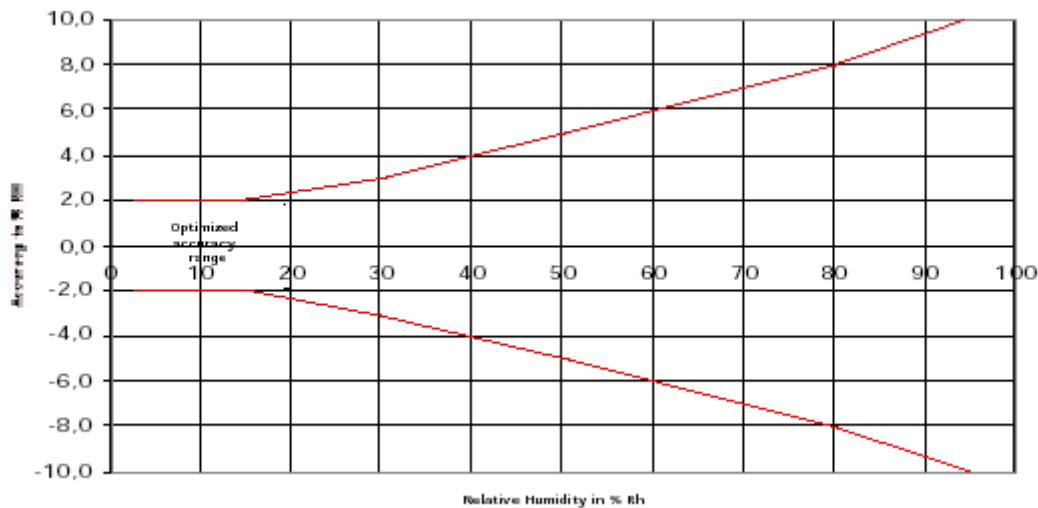

natural parameter (Vs=5.0VDC, RL>1M, Unless otherwise specified)

natural parameter	symbol	Min	Typ	Max	unit
Humidity range /Ta-30 to 60°C	RH	1		99	%RH
Relative humidity accuracy(1~20%RH) at 23°C	RH		+/-2	+/-3	%RH
Relative humidity accuracy 55%RH, 23°C	RH		+/-5%		%RH
supply voltage	Vs	4.75	5.00	5.25	V
output , RH=10%/Ta 25°C	Vout	1.17	1.24	1.31	V
Consumed current	Ic		0.4	0.8	mA
temperature effect (10~50°C, 1~20%RH)	Tcc		<0.1		%RH/°C
Average sensitivity 5%~10%RH	ΔmV/%RH		+26		mV/%RH
output impedance	Z		70		Ohms
Absorption current capacity(RL=15K)	Is			300	microamp
Humidity			+/-1.5		%RH
long-term stability			0.5		%RH/yr
response time (5~10%RH, static state , 63%)	t		5		S

HM1520 for 1~30%RH predicted characteristics

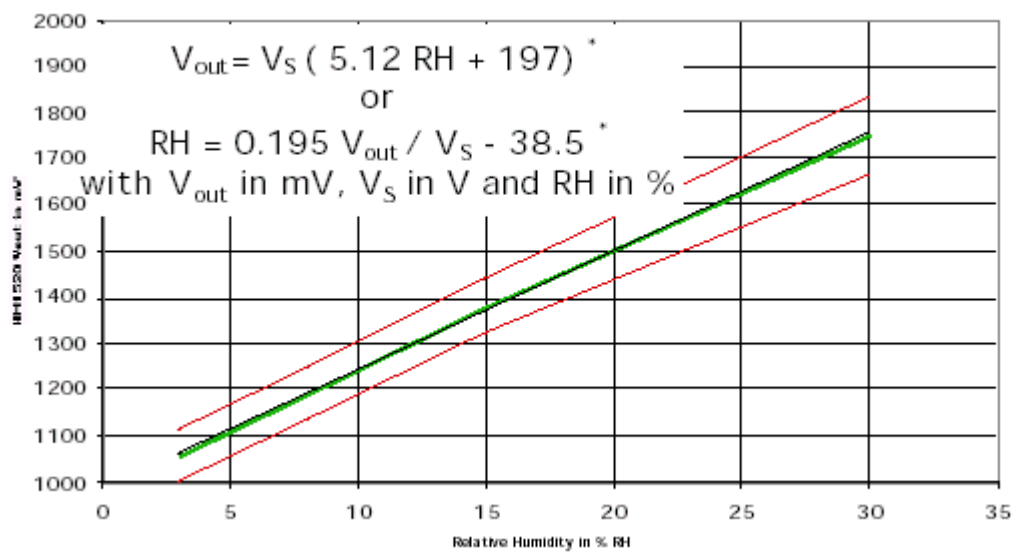

- These equations can be used for more than 30%RH, It also includes the full humidity measurement range of precision on page 1 of this specification.
- 1~30%RH Measuring when, Temperature has no effect on output(0~50°C), No temperature compensation required.

signal output (1 to 20%RH, 23°C):

RH%	0	1	2	3	4	5	6	7	8	9	10
Vout		1013	1038	1064	1089	1115	1141	1166	1192	1217	1243
RH%	11	12	13	14	15	16	17	18	19	20	
Vout	1269	1294	1320	1346	1371	1397	1422	1448	1474	1499	

Power supply 5VDC

Please note:

HM1520 is based on HS1101 capacitive humidity sensor measurement, Therefore, the relative humidity can be tested in full range(1~99%RH), Across the full range, The typical value of HM1520 precision is +/- 5%RH at 55%RH。

HM1520 is an accurate module for low relative humidity detection instruments.

HM1520 is also very suitable for use as a probe to measure water vapor content(ppm) or low dew point.

The H1520 is characterized by the best accuracy at humidity below 6000ppm or at ambient temperature of 23°CThe dew point is 0°C (Equivalent to 20%RH)。

The ambient temperature is 23°C, HM1520 Typical output for measuring humidity

(Vout unit : mV)

ppm	0	275	550	825	1100	1375	1650	1925	2200	2470	2750
Vout		1013	1038	1064	1089	1115	1141	1166	1192	1217	1243
ppm	3025	3300	3570	3850	4120	4395	4670	4945	5220	5495	
Vout	1269	1294	1320	1346	1371	1397	1422	1448	1474	1499	

$$\text{ppm (water)} = 10.75V_{\text{out}} - 10615 \quad V_{\text{out}} \text{ is mV}$$

The ambient temperature is 23°C, HM1520 Typical output for measuring dew point

(Vout unit : mV) °C | | -36 | -29 | -24 | -21 | -18.5 | -16 | -14.5 | -13

| -11.5 | -10 | Vout | | 1013 | 1038 | 1064 | 1089 | 1115 | 1141 | 1166 | 1192

| 1217 | 1243 | °C | -9 | -7.8 | -6.8 | -5.8 | -4.9 | -4.1 | -3.2 | -2.5 | -1.6 | -1.1 | |

Vout | 1269 | 1294 | 1320 | 1346 | 1371 | 1397 | 1422 | 1448 | 1474 | 1499 | _____

Schematic diagram

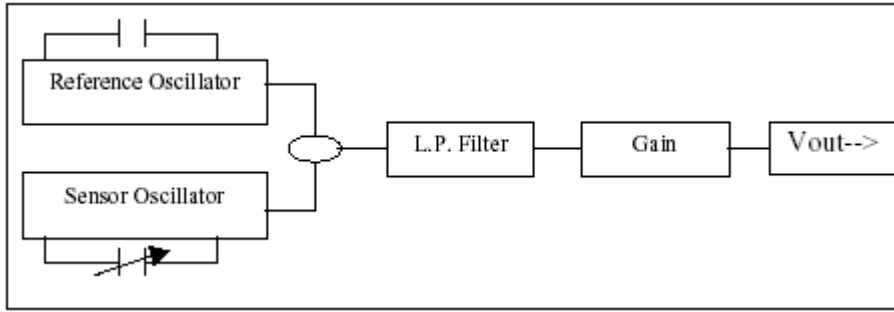

Encapsulation form

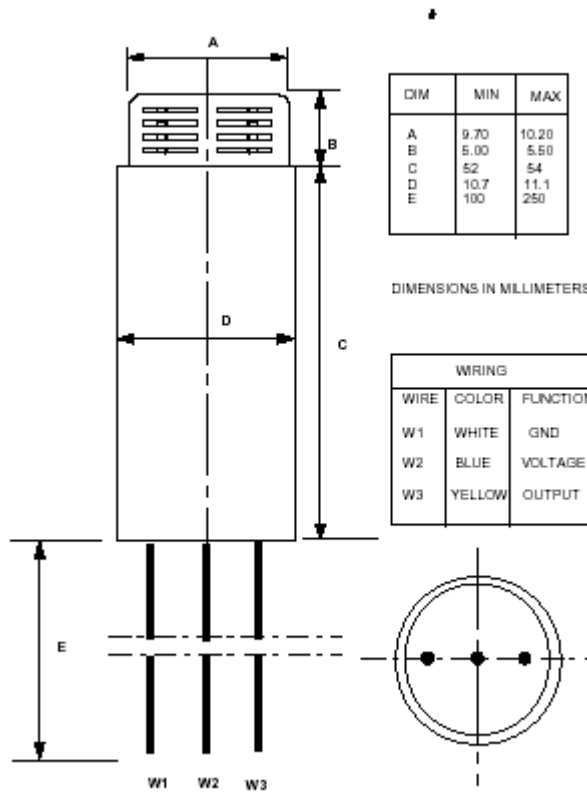

深圳市杰晟兴电子有限公司 JM Components Limited

地址：深圳市福田区中航路7号鼎诚国际大厦南座2007室
 手机：13662266995 马少良 电话：0755-83951311
 官网：cn-sensor.com

邮编：518031
 传真：0755-83952401
 电邮：jackson@jmcomponents.com