

## C20B Carbon Dioxide Sensor

### General Description

The C20B is a carbon dioxide designed specifically for educational applications. The C20B provides fully temperature compensated readings of Carbon Dioxide (CO<sub>2</sub>) concentrations from 0 to 65% , over the temperature range 0-40C.

The C20B has a TTL level digital output showing the instantaneous and averaged CO<sub>2</sub> readings.

The C20B can be run using just four connections - +5V, 0V, Serial In, Serial Out.

Once powered up, it will immediately start to transmit CO<sub>2</sub> readings twice per second. This can be read directly by connecting to a microcontroller, or can be connected to a PC using a suitable serial driver chipset.

The C20B is specifically designed for educational use applications.

and is not suitable for use in other applications.

The C20 family of sensors includes digital and analogue output CO<sub>2</sub> sensors for a wide range of temperature ranges and concentrations.



### Specifications

	Nominal Values	Comments
Detection limits	200ppm	
Noise at zero	20ppm	
Warm Up	120s	
Temperature Range	0C to 40C	
Storage Temp	-30C to +70C	
Supply Voltage	5v	4.7V to 5.5V
Supply Current	20mA	Average. Peak is 220mA
Range	65%	
Output	Serial	9600,n,8,1
Serial Level	4.4V	Vhigh

## Connections

The C20B can be connected *either* using the Molex locking socket, *or* by connection to four plated through holes. The plated through holes can accept standard header 0.1" pitch header pins or wired connections.

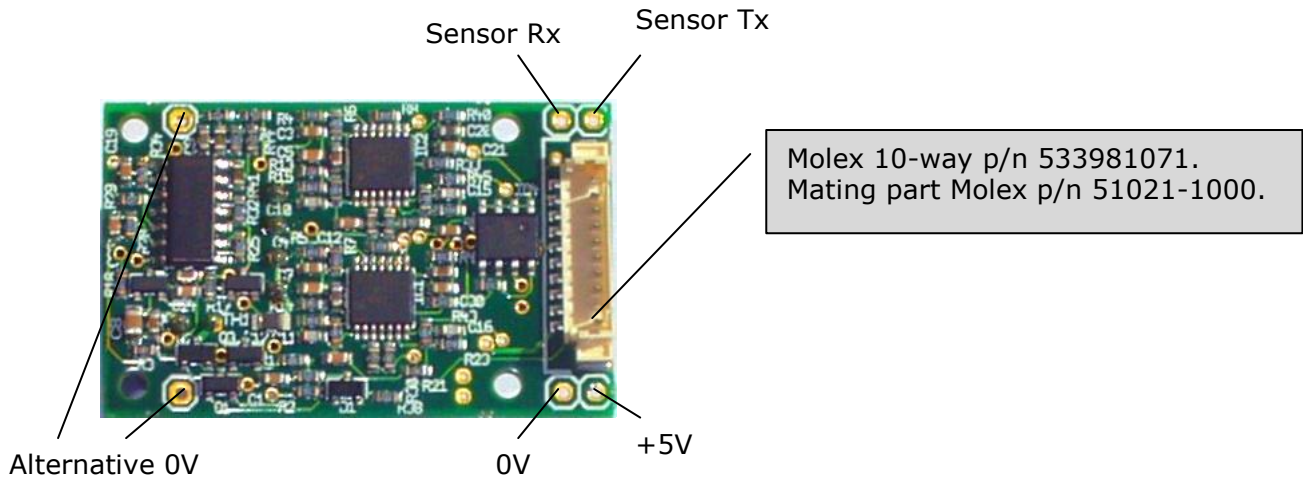

### Through Hole Connections

The through hole connections are simplest to implement:

Connection	Use	Comments
Bottom Right	+5V	Positive supply 4.7v to 5.5v **
Top Right	Serial Transmit	NB inverted
Top Left	Serial Receive	NB inverted Internal pull-up.
Bottom Left	GND	0V

### 10 Way Molex

The Molex connector has the same connections as the through hole, and has additional pins to allow zero calibration to be triggered by hardware.

Pin	Use	Comments
<b>1</b>	<b>+5V</b>	<b>Positive supply 4.7v to 5.5v**</b>
2	N/C	Connect to 0V or leave unconnected
<b>3</b>	<b>Zero</b>	<b>Pull low to zero the unit</b>
4	N/C	Factory calibration use only
<b>5</b>	<b>Serial Transmit</b>	<b>NB inverted</b>
<b>6</b>	<b>Serial Receive</b>	<b>NB inverted Internal pull-up.</b>
7	N/C	Factory calibration use only
8	N/C	Factory calibration use only
<b>9</b>	<b>Air Zero</b>	<b>Pull Low to zero the unit in ambient air.</b>
<b>10</b>	<b>GND</b>	<b>0V</b>

**\*\*NB Do not exceed the maximum supply voltage of 5.5V Please ensure that the supply polarity is correct before power up. Reversing the power leads can cause permanent damage to the sensor.**

## Recommended Connection

This schematic shows a typical connection to a microcontroller. It is assumed that the microcontroller is running at 5v.

The power supply is the circuit used on the GSS Technical Demonstrator. The key requirements are:

- Supply 4.7 to 5.5V
- Supply peak current of 220mA. GSS recommends using a minimum 800mA regulator.
- An output capacitor of at least 47 $\mu$ F.

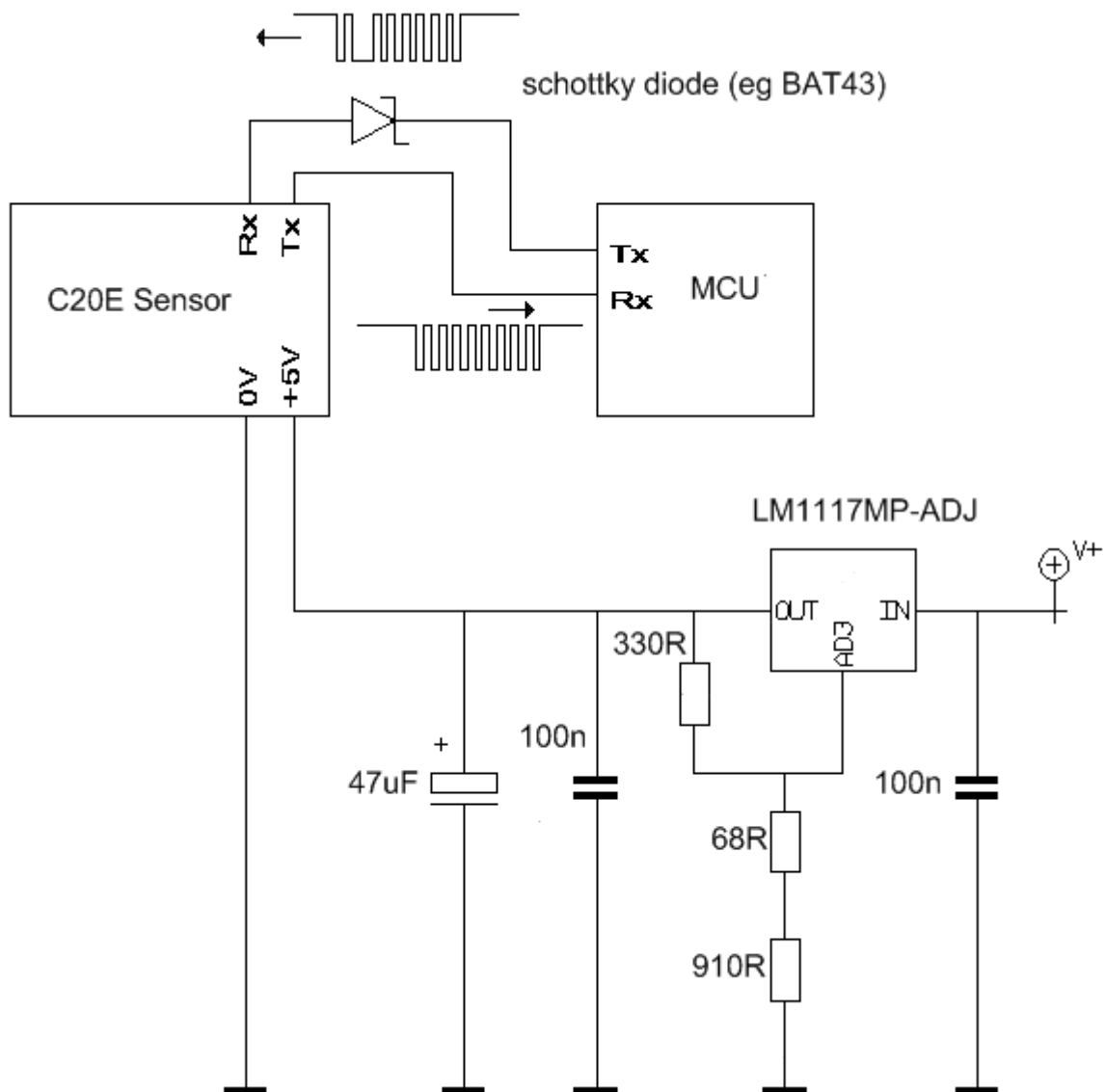

## Sensor Output

The output from the sensor is a simple asynchronous serial output from the Tx connector.

Speed	9600 baud
Number of data bits	8 bit
Parity	no parity
Stop Bits	1 stop bit
V <sub>h</sub>	4.4V
V <sub>l</sub>	0V

### Outputs

The sensor sends the CO<sub>2</sub> concentration twice per second. The C20B provides two outputs – one responds very quickly to changes in CO<sub>2</sub> concentration, and the other integrates this output to give a smoother response which responds more slowly to changes in CO<sub>2</sub>. Both readings are based on the same measurement in the sensor.

In both cases, the concentration is reported in ppm/10. For example, a sensor output of 350 would mean 3500ppm.

The output format is:

```
Z ##### z ##### \r\n
```

For example:

```
Z 00017 z 00020 \r\n
```

Every line is terminated with a carriage return, new line.

```
c      \r\n
hex    0x0d 0x0a
decimal 13 10
```

The first number output (after 'Z') is the smoothed reading, and the second output (after 'z') is the fast response reading.

So "Z 00017 z 00020" would indicate a reading of 170ppm on the smooth output and 200ppm on the fast response output. This example shows a typical trace using both readings.

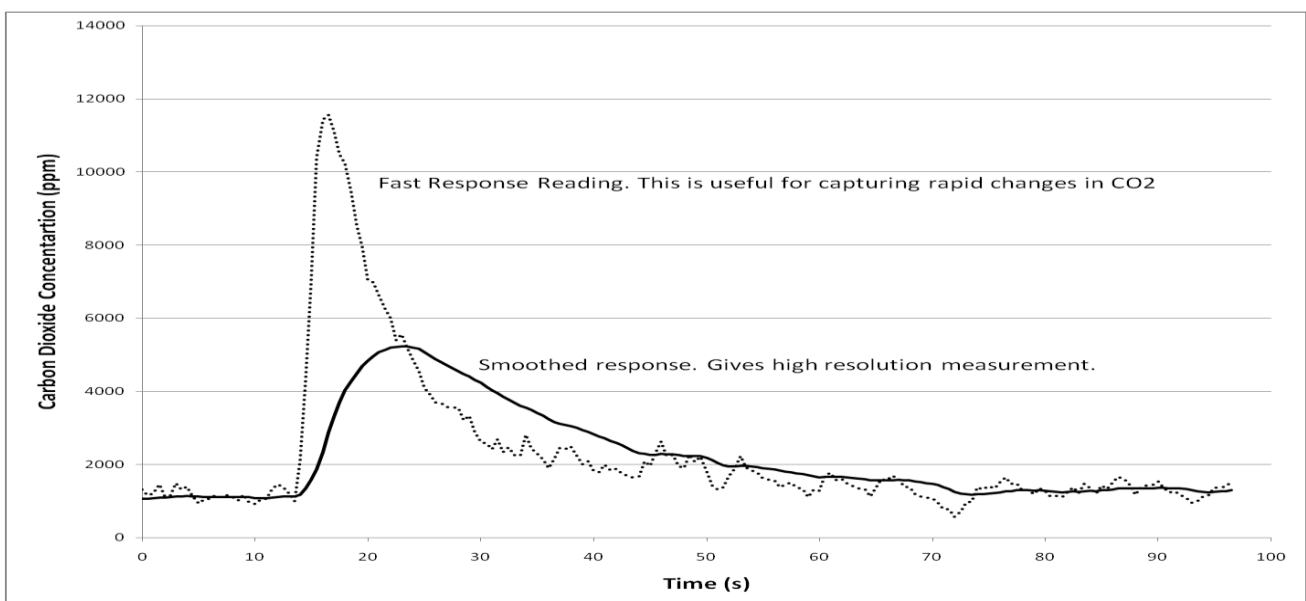

## Zero Point Calibration

The zero for the sensor should be set periodically. It is stored in memory, so does not need to be set every time the unit is switched on.

### Zeroing in Nitrogen (recommended)

- Flow Nitrogen (or another gas free of CO<sub>2</sub>) over the sensor for 30s.
- Pull pin 3 low for at least 1s, **or** send the command "U" to the sensor.
- The sensor will respond by sending "U #####".

If nitrogen is not available, it is possible to calibrate in ambient air (preferably 'outside' air):

### Zeroing in Ambient Air (assumed to be 450ppm)

- Place the unit in ambient air (preferably fresh 'outside' air) and allow it to stabilise for 30s
- Pull pin 9 low for at least 1s **or** send the command "G" to the sensor.
- The sensor will respond by sending "a #####".

## Span Calibration

The C20B is fully factory calibrated before shipping and it should not normally be necessary to carry out a span calibration. However the C20B does have the facility for users to calibrate the full span if required.

The C20B span (full scale reading) can be calibrated by using a calibration gas source. The process is as follows:

- Remove any previous span calibration factor by sending "S 8192 \r\n" to the C20B.
- Ensure that the C20B is correctly zeroed using a nitrogen (or zero gas) source.
- Immerse the gas sensor in a gas of known concentration (eg a calibration gas).
- Allow the gas reading to settle and record the measured gas concentration.
- Now calculate the calibration factor using the formula

$$CF = (AGC * 8192)/MGC \text{ (round to nearest integer)}$$

Where

CF= Calibration Factor

AGC = Actual Gas Concentration

MGC = Measured Gas Concentration

- Finally, enter the correction factor into the C20B using the command

S ##### \r\n

where ##### is the Correction factor calculated in step 4.

For example, if the calibration gas is 10,000ppm, and the reading is 10,200ppm, the value to be entered would be

$$(10000*8192/10200) = 8031$$

i.e. S 8031\r\n

## 深圳市杰晟兴电子有限公司 JM Components Limited

地址：深圳市福田区中航路7号鼎诚国际大厦南座2007室

手机：13662266995 马少良 电话：0755-83951311

官网：cn-sensor.com

邮编：518031

传真：0755-83952401

电邮：jackson@jmcomponents.com