

Installation Instructions for Optomax Basic Series Liquid Level Sensors

GENERAL DESCRIPTION

The LLC Basic Series liquid level sensor provides a single point detection for high volume OEM applications. The sensor contains an infra-red emitter and detector accurately positioned to ensure good optical coupling between the two when the sensor is in air. When the sensor's cone is immersed in liquid, the infra-red light escapes from the cone causing a change in the amount of light at the detector.

This configuration allows the customer to tailor the sensor electronics (supply voltage, protection etc) to their unique application

CLEANING

Proper fluids should be selected based on type of contamination to be removed. Apollosense Ltd recommends freon and alcohol based solvents. DO NOT use chlorinated solvents such as trichloroethane as these are likely to attack the sensor material.

Liquid Media Compatibility

Before use check that the fluid in which you wish to use these devices is compatible with polysulphone.

ELECTRICAL SPECIFICATIONS

Supply voltage (Vs)	Any
Supply current	10 mA nominal
Output Type	Phototransistor (Digital)
Output Signal	See next page.
Operating temperature	-25 °C to 80 °C
Storage temperature	-30 °C to 85 °C

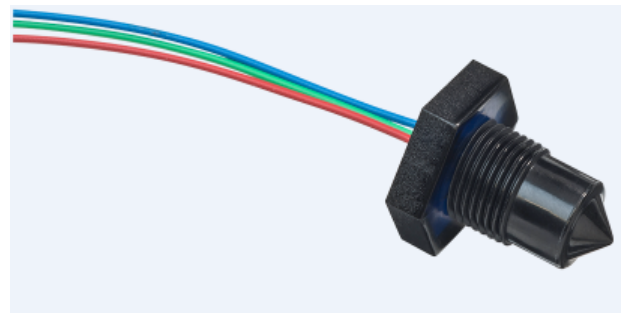

LLC200A3SH

MOUNTING

Catalogue Listing

	LLC200A3SH LLC200A4SH	LLC500A3 LLC500A4	LLC600A3SH LLC600A4SH	LLC700A3SH LLC700A4SH
Standard temperature				
Thread	M12x1x8g with hex nut *	M10x1	1/2" SAE with o-ring *	1/4" NPT
Tightening torque	1.5 N m/13.26 in lb max.			
Pressure (using washer available separately)	7 bar max	20 bar max	7 bar max	7 bar max
Mounting hole	Ø12mm	Ø10mm	Ø 1/2 Inch	1/4 Inch
Housing Material	Polysulphone Trogamid (Replace "C" in part number with "T" for Trogamid Material)			
Sensor Termination	24AWG, 250mm PTFE Wires, 8mm Tinned			

* Hex nut and o-ring sold separately, please contact us for details.

TYPICAL INSTALLATION

Customer has to select suitable resistors for their chosen supply voltage. Forward voltage of LED is 1.3V and LED current should be 10mA (depending on application liquid). Therefore, for a supply of Vs = 5V for example:

$$R_{LED} = \frac{(V_s - 1.3)V}{10mA} = \frac{5 - 1.3}{0.01} = 370\Omega \approx 360\Omega \text{ (standard value)}$$

NOTE: FAILURE TO SELECT CORRECT RESISTOR VALUES MAY RESULT IN DAMAGE TO THE SENSOR !

SCHEMATIC DIAGRAMS

LLC500A3/ LLC200A3SH/ LLC600A3SH

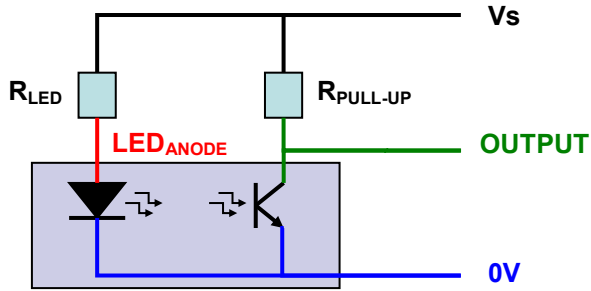

WIRE	DESIGNATION
RED	LED _{ANODE}
GREEN	OUTPUT
BLUE	0V

LLC500A4/ LLC200A4SH/ LLC600A4SH

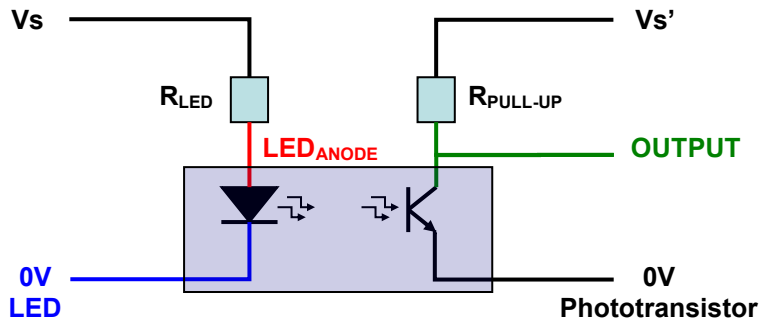

WIRE	DESIGNATION
RED	LED _{ANODE}
GREEN	OUTPUT
BLUE	0V LED
BLACK	0V Phototransistor

Note: The 4-wire version provides galvanic isolation between input (IR-LED) and output (Phototransistor).

Pre-selected R_{LED} and $R_{PULL-UP}$ Value for different Supply Voltages				
V_s	R_{LED}	$R_{PULL-UP}$	V_{OUTPUT} in Air	V_{OUTPUT} in Water
3.3V	200R	2K	< 0.75V	> 2.5V
5V	360R	2K	< 1V	> 4.25V
8V	680R	2.5K	< 1.5V	> 7.25V
12V	1K	3K	< 3V	> 11.25V
15V	1.3K	3.5K	< 3.25V	> 14.25V
24V	2.2K	4K	< 10.5V	> 22.5V

PRODUCT DIMENSIONS

(All dimensions in mm)

LLC500 Series

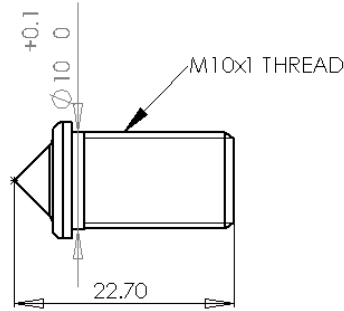
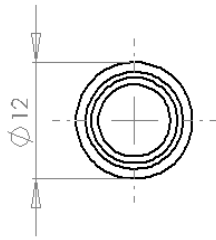

LLC200 Series

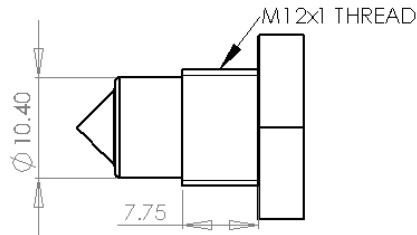
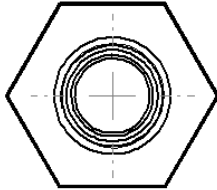

LLC600 Series

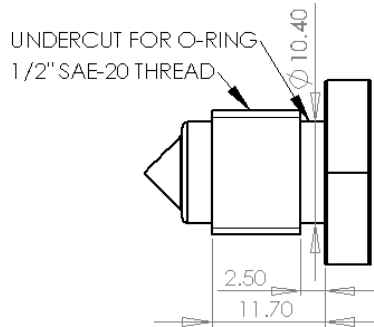
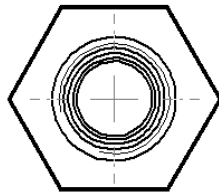

LLC700 Series

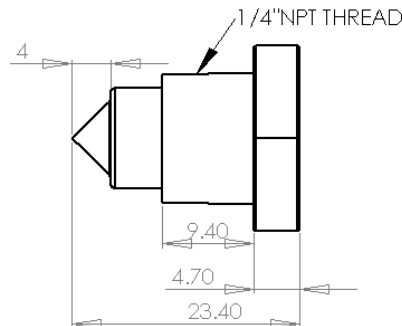
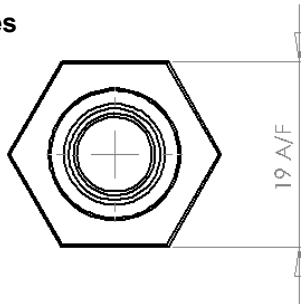

WARNING

All Apollosense Ltd products are tested under nominal operating conditions during the production process. Applications for our products are varied and, as these are outside our control, specification information provided is given without legal responsibility. Customers should test under their own conditions, to ensure that the sensors are suitable for their intended application.

CAUTION

Do not exceed maximum ratings. Carefully follow all wiring instructions, incorrect wiring can cause permanent damage to the device. Do not use chemical cleaning agents.

Failure to comply with these instructions may result in product damage.

General Note: Apollosense Ltd reserves the right to make changes in product specifications without notice or liability. All information is subject to Apollo's own data and considered accurate at time of going to print.

深圳市杰晟兴电子有限公司 JM Components Limited

地址：深圳市福田区中航路7号鼎诚国际大厦南座2007室
手机：13662266995 马少良 电话：0755-83951311
官网：cn-sensor.com

邮编：518031
传真：0755-83952401
电邮：jackson@jmcomponents.com