

## TGS6812-D00 Gas Sensor for Detecting Hydrogen, Methane and LP

### characteristic : \_\_\_\_\_

- \* linear output
- \* Long service life
- \* Low sensitivity to alcohol
- \* High sensitivity to hydrogen, methane and LP

### apply : \_\_\_\_\_

- \* Used to monitor hydrogen and combustible gas leaks in fuel cells

The TGS6812-D00 catalytic combustion gas sensor detects hydrogen at 100%LEL levels with exceptional accuracy, durability, and stability. Featuring rapid response and linear output, it effectively monitors hydrogen while also detecting methane and liquefied petroleum gas (LPG). This solution proves particularly effective for leak detection in stationary fuel cell systems using hydrogen as the combustible gas.

The TGS6812-D00 has an adsorbent in the cap, which is very cross-sensitive to organic vapors. In addition, the sensor is more tolerant of silicon compounds and more adaptable to harsh environments.



### Sensitivity characteristics: \_\_\_\_\_

The representative sensitivity characteristic curve is shown in the figure below under standard test conditions (see back).

The vertical axis indicates the output sensitivity of the sensor- $\Delta V_{out}$  (mV):  $\Delta V_{out} = V_{out}(\text{gas}) - V_{out}(\text{air})$

### temperature characteristic : \_\_\_\_\_

The figure below shows the representative temperature characteristic curve measured at 65%RH. The vertical axis represents the output sensitivity of the sensor- $\Delta V_{out}$  (mV):

$$\Delta V_{out} = V_{out}(\text{gas}) - V_{out}(20^\circ\text{C air})$$

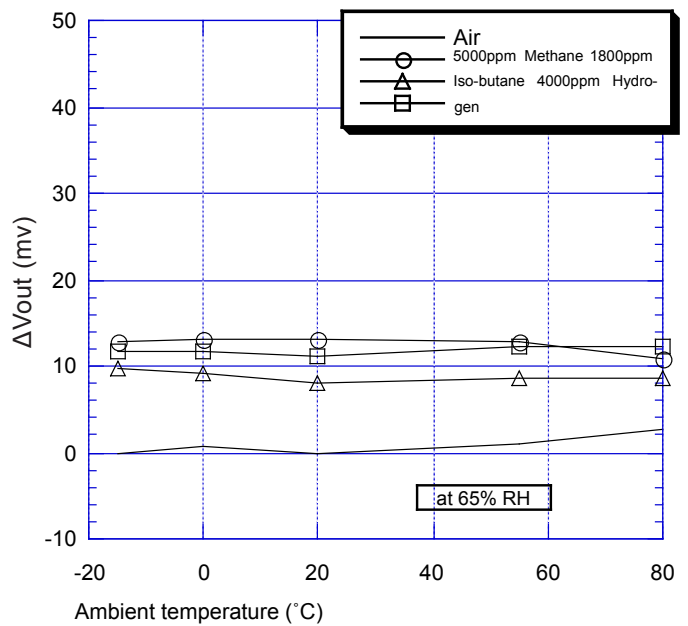
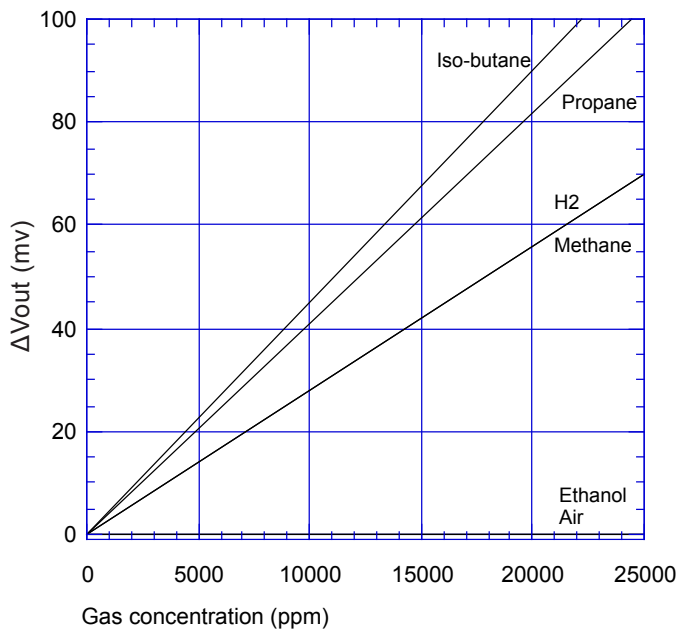

### Basic test circuit:

The TGS6812 consists of two elements: 1) a sensing element (D) highly sensitive to combustible gases; and 2) a reference element (C) insensitive to combustible gases. These elements are installed in a "balance bridge". In a free combustible gas environment, the variable resistance can be adjusted to generate a stable reference signal from the bridge. When combustible gases burn, the temperature of the sensing element rises, causing its resistance to increase. Consequently, the unbalanced signal is transmitted through the bridge and converted into a measurable output voltage.

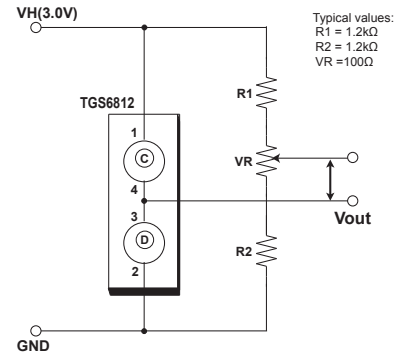

### specifications :

model		TGS 6812-D00	
Detection principle		Catalytic type	
Object gas		Hydrogen, methane, isobutane	
Typical test range		0-100% LEL gases	
Standard loop conditions	working voltage	3.0±0.1V AC/DC	
Electrical characteristics under standard test conditions	Heater current	175mA (typical)	
	Heater power consumption	525mW (typical)	
	wandering of zero point	-15 ~ +55mV	
	Output sensitivity (ΔVout)	hydrogen	8~ 16mV at 4000ppm
		methane	10~ 18mV at 5000ppm
		isobutane	5~11mV at 1800ppm
standard test conditions	Test gas conditions	Hydrogen, methane, isobutane in air 20±2. C, 65±5%RH	
	Circuit conditions	3.0±0.05V AC/DC	
	Pre-test debugging	≤ 30 sec.	
going		-10. C~+70. C, ≤95%RH (no condensation)	
maintaining requirement		-10. C~+80. C, ≤95%RH (no condensation)	

### Structure and size:

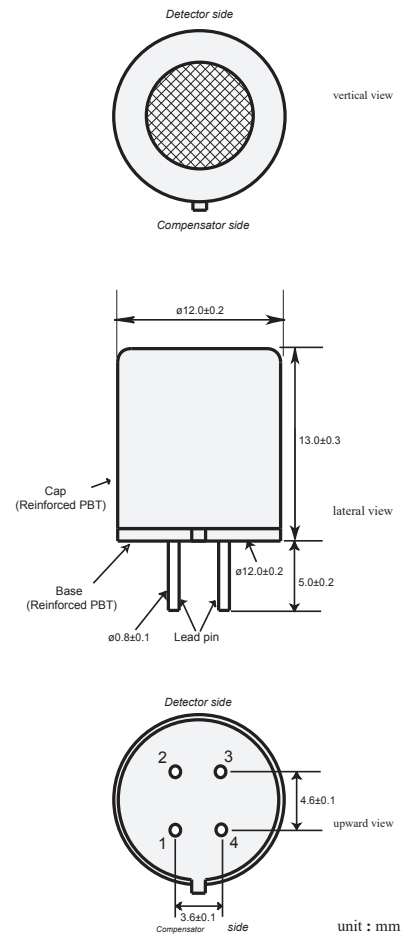

Pin connections:  
1-4: Compensation elements  
2-3: Detection elements

All sensor characteristics shown in this product introduction are typical characteristics, and the actual characteristics vary from sensor to sensor. The above characteristics table is the only guarantee.

## 深圳市杰晟兴电子有限公司 JM Components Limited

地址: 深圳市福田区中航路7号鼎诚国际大厦南座2007室  
手机: 13662266995 马少良 电话: 0755-83951311  
官网: cn-sensor.com

邮编: 518031  
传真: 0755-83952401  
电邮: jackson@jmcomponents.com