

NO-AE Nitric Oxide Sensor High Concentration

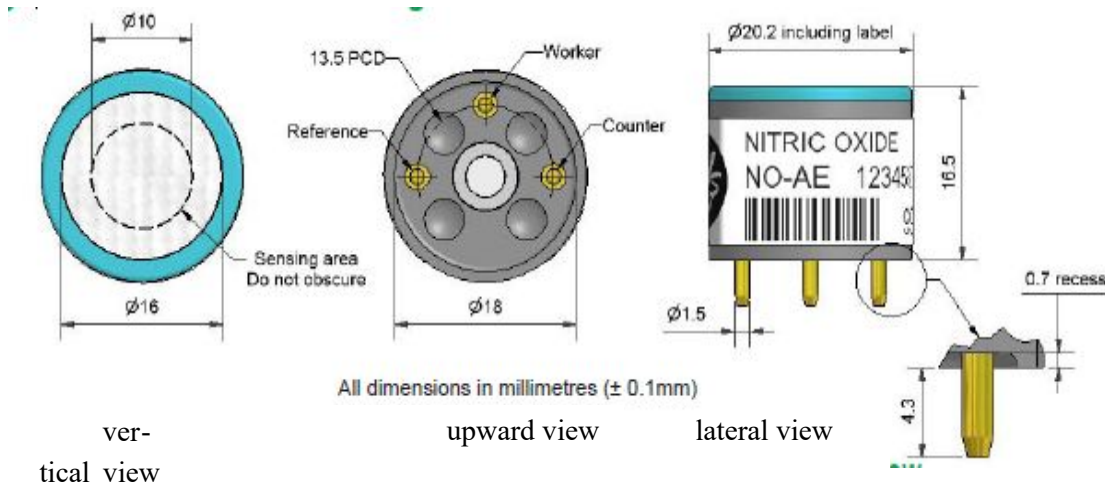

Figure 1 NO-AE Schematic Diagram



function	sensitivity	Sensitivity in 250ppmNO (nA/ppm)	40~80
	reaction time	Time from zero to 250ppmNO t90 (s)	< 75
	zero current	Equivalent ppm value in zero air	0~15
	resolution ratio	RMS noise (equivalent ppm value)	< 1
	range	Measuring limits (ppm) that guarantee product performance	5000
	degree of linearity	The ppm value of the full scale error is linear from 0 to 1000ppm	< 250
	overload	Maximum ppm value of gas pulse stabilized reaction	10000
life span	zero drift	Equivalent ppm values that change in the laboratory air from year to year	nd
	sensitivity drift	Percentage change in laboratory air over the year, measured monthly	nd
	working life	Number of months to which the output is reduced to 80% of the original signal (24 months guaranteed)	> 24
environment	-20°C sensitivity	50ppmNO when, (output at -20°C/ output at 20°C)%	65~90
	Sensitivity at 50°C	50ppmNO when, (50°C output/20°C output)%	103~112
	-20°C when zero point	Change in equivalent ppm values with reference to 20°C zero	<0~-3
	50°C at zero point	Change in equivalent ppm values with reference to 0°C 20	<10~40
cross sensitivity	H ₂ S	Gas sensitivity percentage at 20ppmH ₂ S	< 50
	NO ₂	Gas sensitivity percentage ₂ at 50ppmNO	< 20
	Cl ₂	Sensitivity percentage of gas measured ₂ at 10ppmCl	< 25
	SO ₂	Gas sensitivity percentage ₂ at 20ppmSO	< 5
	CO	Gas sensitivity percentage measured at 400ppmCO	< 0.1
	H ₂	Gas sensitivity percentage measured at 400ppmH ₂	< 0.1
	C ₂ H ₄	Gas sensitivity percentage measured at 400ppmC ₂ H ₄	< 0.1
	NH ₃	Percentage sensitivity of gas ₃ at 20ppmNH	< 0.1
CO ₂	5%Vol CO ₂ when measured percentage sensitivity of gas	< 0.1	
key parameter	temperature range	°C	-30~50
	pressure limit	kPa	80~120
	Humidity range	Percentage of continuous relative humidity	15~90
	Storage period	Number of months for preservation from 3 to 20°C (to be kept in a sealed tank)	6
	bias voltage	mV (working electrode potential greater than zero)	+300
	load resistance	Ω (recommend)	10~47
	weight	g	< 6

Figure 2 Sensitivity Temperature Characteristics

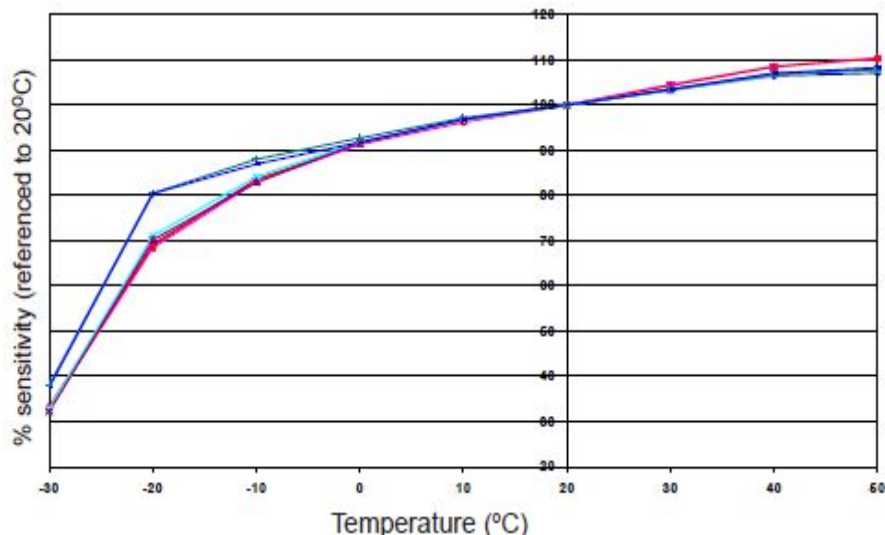

Figure 2 shows the change in sensor sensitivity caused by temperature changes.

Data was collected from typical batch sensors.

Figure 3 Zero Temperature Characteristics

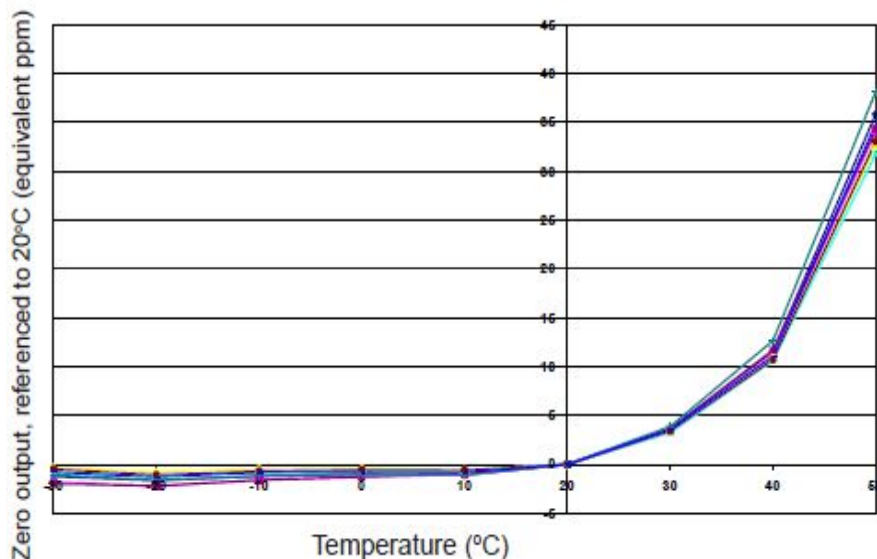

Figure 3 shows the change in zero point output caused by temperature changes, expressed as equivalent ppm values, with reference to the zero point at 20°C.

Data was taken from a typical batch of sensors.

Figure 4. Response of the Sensor to 0-1% NO

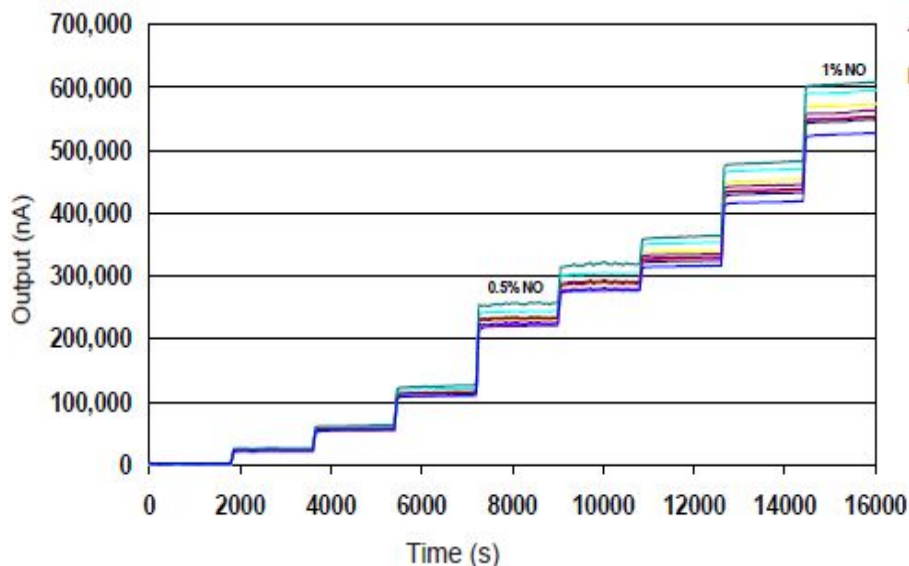

Figure 4 shows the rapid and stable response of NO-AE sensor in the environment of 0-1% NO.