

## HCL-B1 Hydrogen Chloride Sensor

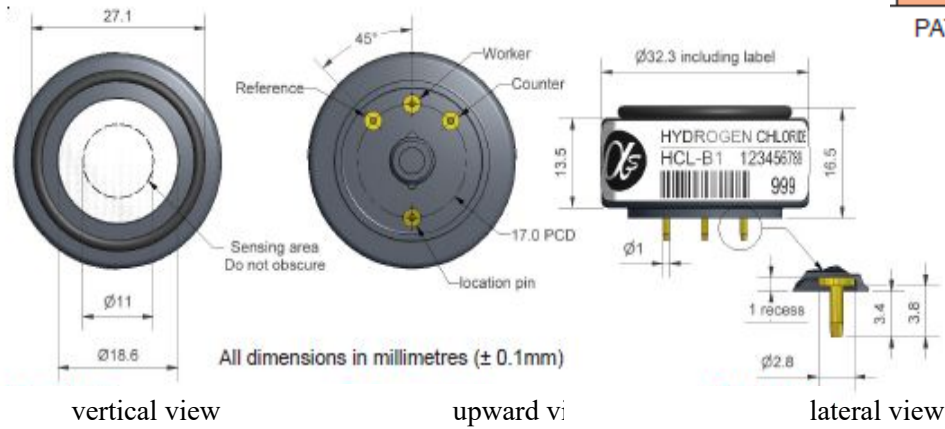

PATENTED

Figure 1 HCL-B1 Schematic Diagram



function	sensitivity	Sensitivity in 25ppmHCl (nA/ppm)	120~250
	reaction time	t90 time from zero to 25ppmHCl (s)	< 200
	zero current	Equivalent ppm value of zero air	-0.6~5
	resolution ratio	RMS noise (equivalent ppm value)	< 0.1
	range	Measuring limits (ppm) that guarantee product performance	100
	degree of linearity	The ppm value of the full scale error is linear from 0 to 40ppm	0~6
	overload	Maximum ppm value of gas pulse stabilized reaction	200
life span	zero drift	Equivalent ppm values that change in the laboratory air from year to year	nd
	sensitivity drift	Percentage change in laboratory air over the year, measured monthly	nd
	working life	Number of months output drops to 80% of original signal (12 months guaranteed)	nd
environment	-20°C when sensitivity	25ppmHCl when, (-20°C output/20°C output)%	80~95
	Sensitivity at 50°C	25ppmHCl when, (50°C output/20°C output)%	100~108
	-20°C when zero point	Change in equivalent ppm values with reference to 20°C zero	< 0~-1.0
	50°C at zero point	Change in equivalent ppm values with reference to 20°C zero	< 0.5~2.5
cross sensitivity	H <sub>2</sub> S	Percentage sensitivity of gas measured at 2 p <sub>2</sub> HmH	< 280
	NO <sub>2</sub>	Percentage sensitivity of gas measured at 2 p <sub>2</sub> MNO	< -150
	Cl <sub>2</sub>	Percentage sensitivity of gas measured at 2 p <sub>2</sub> ppmCl	< -100
	NO	Percentage of gas sensitivity measured at ppmNO	< 2
	SO <sub>2</sub>	Percentage sensitivity of gas measured at 2 p <sub>2</sub> SO (transient peak)	< 1
	CO	Percentage of gas sensitivity measured at ppmCO	< 0.1
	H <sub>2</sub>	Percentage sensitivity of gas measured at 2 p <sub>2</sub> H	< 0.1
	C <sub>2</sub> H <sub>4</sub>	Percentage sensitivity of gas measured at ppmC <sub>2,4</sub>	< 0.1
	NH <sub>3</sub>	Percentage sensitivity of gas measured at ppmNH <sub>3</sub>	< 0.1
CO <sub>2</sub>	Gas sensitivity percentage <sub>2</sub> measured at 5%CO	< 0.1	
key parameter	temperature range	°C	-30~50
	pressure limit	kPa	80~120
	Humidity range	Percentage of continuous relative humidity	15~90
	Storage period	Number of months for preservation from 3 to 20°C (to be kept in the original container)	6
	load resistance	Ω ( recommend )	10~33
	bias voltage	mV	non-essential
weight	g	< 13	

Figure 2 Sensitivity Temperature Characteristics

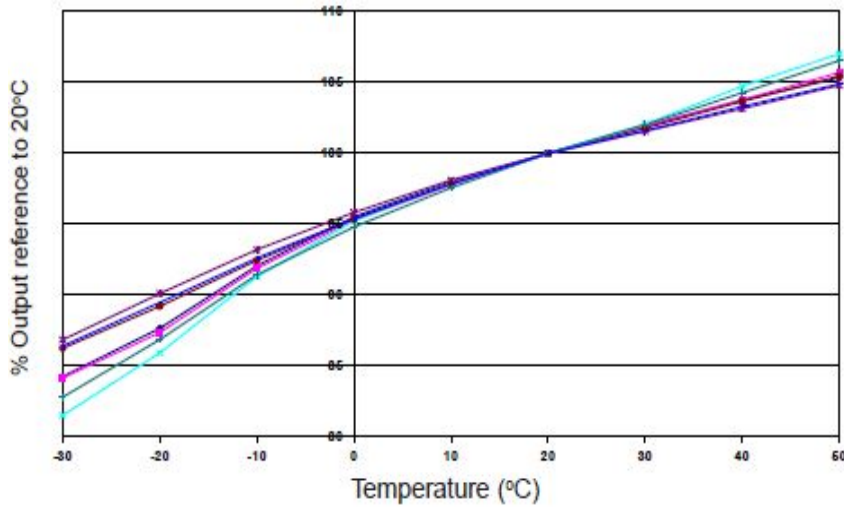

Figure 2 shows the change in sensitivity of the transducer to 25ppm HCl with temperature variation.

Figure 3 Zero Temperature Characteristics

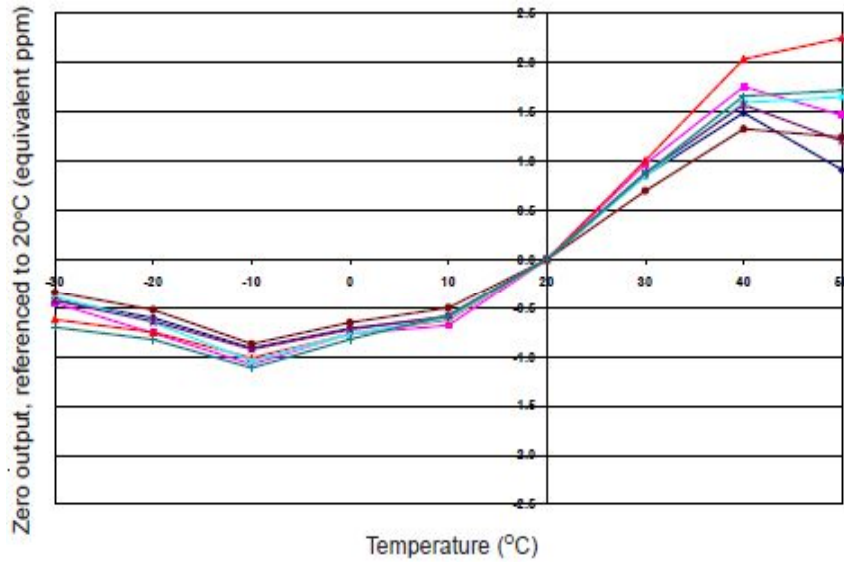
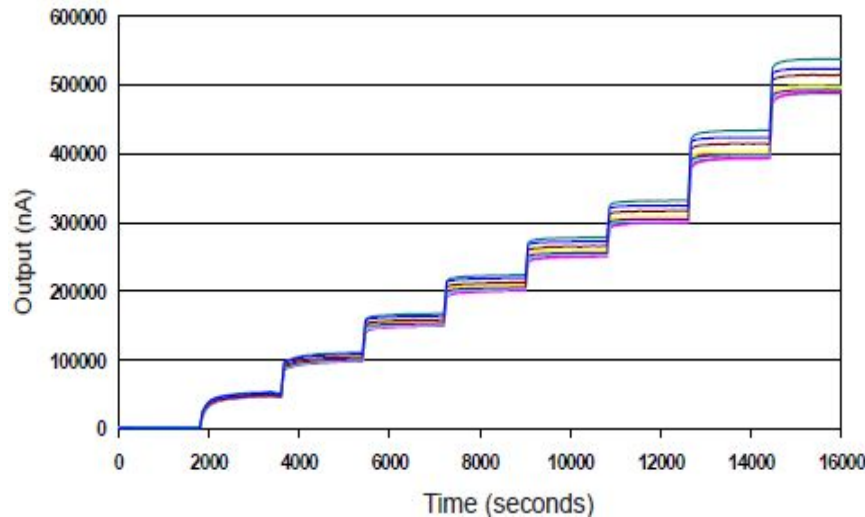

Figure 3 shows the change in zero point output caused by temperature changes, expressed as equivalent ppm values, with reference to the zero point of 20°C.

Data is taken from a typical batch of sensors.

Figure 4 Reaction at 200ppm HCl



Transmitter for 200ppm

The reaction with HCl was good.

**深圳市杰晟兴电子有限公司 JM Components Limited**