

## Humidity Sensors Humidity Sensor

## HIH-3610 Series

### FEATURES

- Molded thermoset plastic housing with cover
- Linear voltage output vs %RH
- Laser trimmed interchangeability
- Low power design
- High accuracy
- Fast response time
- Stable, low drift performance
- Chemically resistant

### TYPICAL APPLICATIONS

- Refrigeration
- Drying
- Metrology
- Battery-powered systems
- OEM assemblies

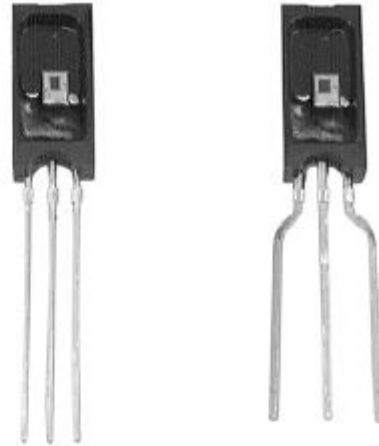

The HIH-3610 Series humidity sensor is designed specifically for high volume OEM (Original Equipment Manufacturer) users. Direct input to a controller or other device is made possible by this sensor's linear voltage output. With a typical current draw of only 200  $\mu$ A, the HIH-3610 Series is ideally suited for low drain, battery operated systems. Tight sensor interchangeability reduces or eliminates OEM production calibration costs. Individual sensor calibration data is available.

The HIH-3610 Series delivers instrumentation-quality RH (Relative Humidity) sensing performance in a low cost, solderable SIP (Single In-line Package). Available in two lead spacing configurations, the RH sensor is a laser trimmed thermoset polymer capacitive sensing element with on-chip integrated signal conditioning. The sensing element's multilayer construction provides excellent resistance to application hazards such as wetting, dust, dirt, oils, and common environmental chemicals.

### ▲WARNING

#### PERSONAL INJURY

- DO NOT USE these products as safety or emergency stop devices, or in any other application where failure of the product could result in personal injury.

**Failure to comply with these instructions could result in death or serious injury.**

### ▲WARNING

#### MISUSE OF DOCUMENTATION

- The information presented in this product sheet is for reference only. Do not use this document as system installation information
- Complete installation, operation, and maintenance information is provided in the instructions supplied with each product.

**Failure to comply with these instructions could result in death or serious injury.**

# Humidity Sensors

## Humidity Sensor

HH-3610 Series

**TABLE 1: PERFORMANCE SPECIFICATIONS**

Parameter	Condition
RH Accuracy <sup>(1)</sup>	±2% RH, 0-100% RH non-condensing, 25 °C, V <sub>supply</sub> = 5 Vdc
RH Interchangeability	±5% RH, 0-60% RH; ±8% @ 90% RH typical
RH Linearity	±0.5% RH typical
RH Hysteresis	±1.2% RH span maximum
RH Repeatability	±0.5% RH
RH Response Time, 1/e	15 sec in slowly moving air at 25 °C
RH Stability	±1% RH typical at 50% RH in 5 years
<b>Power Requirements</b>	
Voltage Supply	4 Vdc to 5.8 Vdc, sensor calibrated at 5 Vdc
Current Supply	200 µA at 5 Vdc
<b>Voltage Output</b>	
	V <sub>out</sub> = V <sub>supply</sub> (0.0062(Sensor RH) + 0.16), typical @ 25 °C (Data printout option provides a similar, but sensor specific, equation at 25 °C.)
V <sub>supply</sub> = 5 Vdc	0.8 Vdc to 3.9 Vdc output @ 25 °C typical
<b>Drive Limits</b>	
	Push/pull symmetric; 50 µA typical, 20 µA minimum, 100 µA maximum Turn-on ≤ 0.1 sec
<b>Temperature Compensation</b>	
	True RH = (Sensor RH)/(1.093-0.0012T), T in °F True RH = (Sensor RH)/(1.0546-0.00216T), T in °C
Effect @ 0% RH	±0.007 %RH/°C (negligible)
Effect @ 100% RH	-0.22% RH/°C (<1% RH effect typical in occupied space systems above 15 °C (59 °F))
<b>Humidity Range</b>	
Operating	0 to 100% RH, non-condensing <sup>(1)</sup>
Storage	0 to 90% RH, non-condensing
<b>Temperature Range</b>	
Operating	-40 °C to 85 °C (-40 °F to 185 °F)
Storage	-51 °C to 125 °C (-60 °F to 257 °F)
Package <sup>(2)</sup>	Three pin, solderable SIP in molded thermoset plastic housing with thermoplastic cover
Handling	Static sensitive diode protected to 15 kV maximum

**Notes:**

1. Extended exposure to ≥90% RH causes a reversible shift of 3% RH.
2. This sensor is light sensitive. For best results, shield the sensor from bright light.



# Humidity/Moisture Sensors

## Humidity Sensor

*HIH-3610 Series*

### FACTORY CALIBRATION

HIH-3610 sensors may be ordered with a calibration and data printout (Table 2). See order guide on back page.

**TABLE 2: EXAMPLE DATA PRINTOUT**

Model	HIH-3610-001
Channel	92
Wafer	030996M
MRP	337313
Calculated values at 5 V	
V <sub>out</sub> @ 0% RH	0.958 V
V <sub>out</sub> @ 75.3% RH	3.268 V
Linear output for 2% RH accuracy @ 25 °C	
Zero offset	0.958 V
Slope	30.680 mV/%RH
RH	(V <sub>out</sub> -zero offset)/slope (V <sub>out</sub> -0.958)/0.0307
Ratiometric response for 0 to 100% RH	
V <sub>out</sub>	V <sub>supply</sub> (0.1915 to 0.8130)

**FIGURE 1: RH SENSOR CONSTRUCTION**

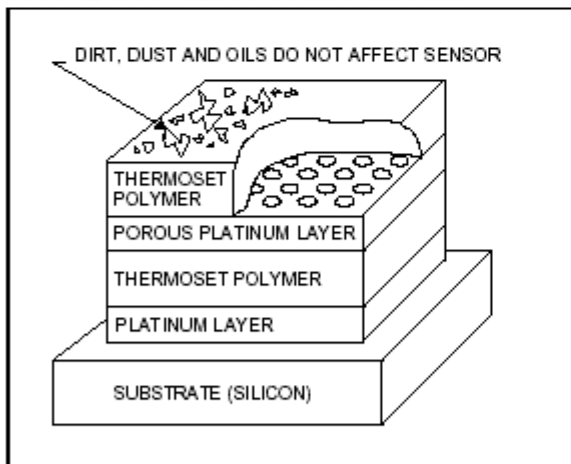

**FIGURE 2: OUTPUT VOLTAGE VS RELATIVE HUMIDITY AT 0 °C**

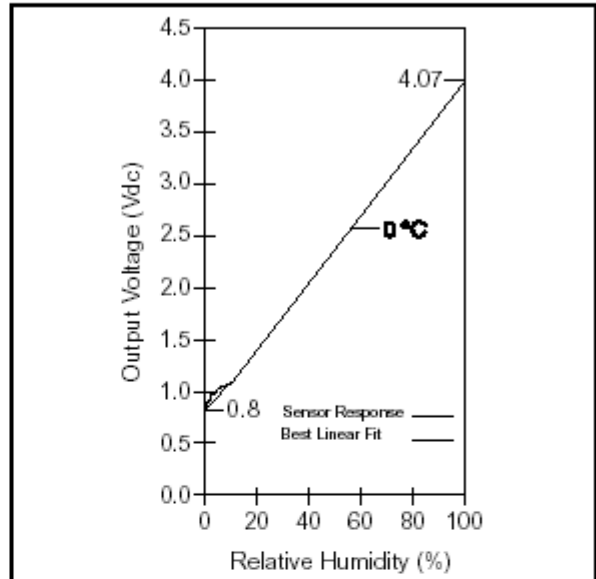

**FIGURE 3: OUTPUT VOLTAGE VS RELATIVE HUMIDITY AT 0 °C, 25 °C, 85 °C**

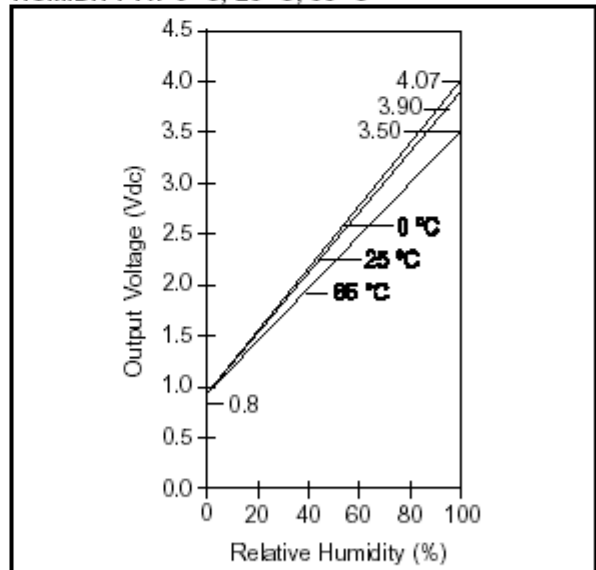

# Humidity/Moisture Sensors

## Humidity Sensor

## HIH-3610 Series

### ORDER GUIDE

Catalog Listing	Description
HIH-3610-001	Integrated circuit humidity sensor, 0.100 in lead pitch SIP
HIH-3610-002	Integrated circuit humidity sensor, 0.050 in lead pitch SIP
HIH-3610-003	Integrated circuit humidity sensor, 0.100 in lead pitch SIP with calibration and data printout
HIH-3610-004	Integrated circuit humidity sensor, 0.050 in lead pitch SIP with calibration and data printout

### WARRANTY/REMEDY

Honeywell warrants goods of its manufacture as being free of defective materials and faulty workmanship. Contact your local sales office for warranty information. If warranted goods are returned to Honeywell during the period of coverage, Honeywell will repair or replace without charge those items it finds defective. The foregoing is Buyer's sole remedy and is in lieu of all other warranties, expressed or implied, including those of merchantability and fitness for a particular purpose.

Specifications may change without notice. The information we supply is believed to be accurate and reliable as of this printing. However, we assume no responsibility for its use.

While we provide application assistance personally, through our literature and the Honeywell web site, it is up to the customer to determine the suitability of the product in the application.

For application assistance, current specifications, or name of the nearest Authorized Distributor, check the Honeywell web site or call:

1-800-537-6945 USA  
1-800-737-3360 Canada  
1-815-235-6847 International  
FAX

1-815-235-6545 USA

### INTERNET

[www.honeywell.com/sensing](http://www.honeywell.com/sensing)  
[info.sc@honeywell.com](mailto:info.sc@honeywell.com)

FIGURE 4: MOUNTING DIMENSIONS (for reference only) mm (in)

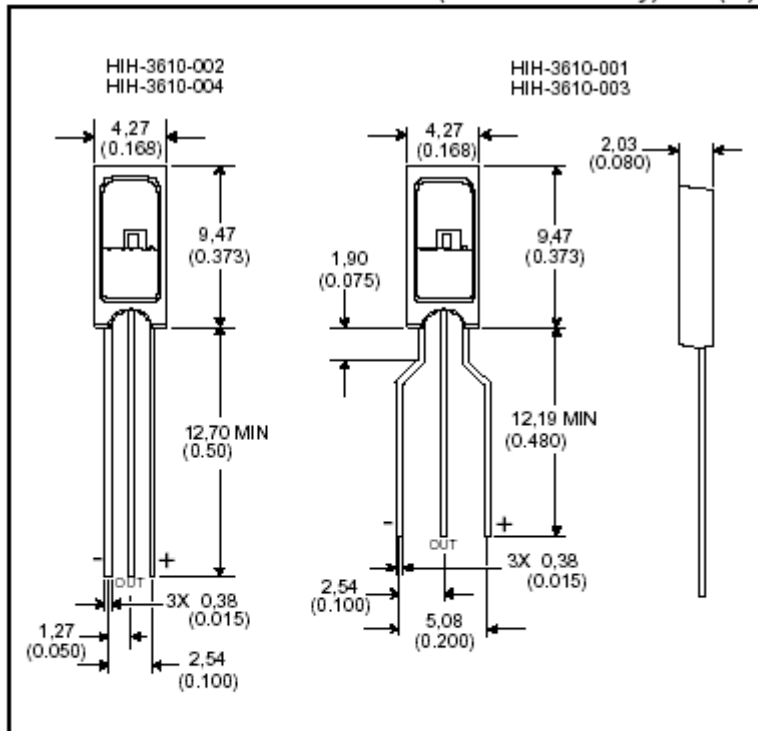

## 深圳市杰晟兴电子有限公司 JM Components Limited

地址：深圳市福田区中航路7号鼎诚国际大厦南座2007室

手机：13662266995 马少良 电话：0755-83951311

官网：[cn-sensor.com](http://cn-sensor.com)

邮编：518031

传真：0755-83952401

电邮：[jackson@jmcomponents.com](mailto:jackson@jmcomponents.com)